

Type 3AB / 3ABP
Fast Blow Fuse Series

1/4 x 1 1/4 inch Ceramic Tube
RoHS Compliant

3ABD1005

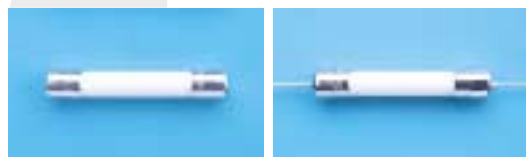

Electrical Characteristics (ULICSA STD. 248-14)

Testing Current	Blow Time	
	Minimum	Maximum
100%	4 Hrs.	N/A
135%	N/A	1 Hr
200%	N/A	5 sec



Approvals

Safety Agency Approvals	Type	Amp range / Volt @ I.R. ability
<ul style="list-style-type: none"> UL_{US} Listed File No. E20624 SP Certified File No. LR39772 	3AB / 3ABP	100mA - 1A / 250V AC@ 35A >1A - 3.5A / 250V AC@ 100A >3.5A - 10A / 250V AC@ 200A 100mA - 10A / 125V AC@ 10,000A
<ul style="list-style-type: none"> File No. JET1037-31003-1001, JET1037-31003-1003 File No. JET1037-31003-1002 	3AB / 3ABP	1A -5A / 125V AC@ 500A
	3AB	>5A - 15A /125V AC@ 300A

RoHS Compliant Product

For RoHS compliant version ,add suffix " R " after catalog number

Operating Temperature

-55°C to +125°C

Physical Specification

Materials

Ceramic body / Nickel Plated Brass Caps

Lead wire:

Tin plated Copper, Diameter 0.040" for all ratings

Marking

On fuse:

"bel", "3AB", "Current Rating", "Voltage Rating", "Appropriate Safety Logos", "✓" (RoHS Version)

On label:

"bel", "3AB" or "3ABP", "Current Rating", "Voltage Rating", "Interrupting Rating", "Appropriate Safety Logos" and "✓" + suffix "R" for RoHS Version

Voltage on fuse:

125V and 250V for 750mA - 15A rating, 250V for below 750mA rating

Packaging

1. In bulk:

3AB - 1,000 pcs per box; 3ABP - 500 pcs per box

2. On Axial Tape & Reel:

1,000 pcs per reel

3. Tape & Reel specification:

per EIA-296-E & IEC 286-1

@ 10mm Pitch and 73mm inside Tape Spacing

Catalog Number	RoHS Suffix	Ampere Rating	Typical Cold Resistance (ohm)	Volt-drop @100% In (Volt) max.	Melting I ² T < 10 mSec (A ² Sec)	Melting I ² T @10 In (A ² Sec)	Maximum Power Dissipation (W)
3AB (P) 100	-R	100mA	12.5	4.5	0.002	0.002	0.59
3AB (P) 125	-R	125mA	12.0	4.5	0.004	0.003	0.74
3AB (P) 160	-R	160mA	8.3	4.2	0.008	0.005	0.87
3AB (P) 200	-R	200mA	5.7	3.9	0.014	0.010	1.02
3AB (P) 250	-R	250mA	3.9	3.6	0.025	0.017	1.19
3AB (P) 300	-R	300mA	2.7	3.4	0.044	0.032	1.40
3AB (P) 375	-R	375mA	2.0	3.2	0.07	0.05	1.58
3AB (P) 500	-R	500mA	0.75	1.1	0.14	0.10	1.92
3AB (P) 750	-R	750mA	0.24	0.2	0.75	0.74	0.30
3AB (P) 1	-R	1A	0.16	0.23	1.43	1.44	0.37
3AB (P) 1.25	-R	1.25A	0.114	0.21	2.45	2.51	0.44
3AB (P) 1.6	-R	1.6A	0.084	0.20	4.2	4.4	0.51
3AB (P) 2	-R	2A	0.063	0.18	7.2	7.6	0.59
3AB (P) 2.5	-R	2.5A	0.047	0.170	12	13	0.70
3AB (P) 3	-R	3A	0.035	0.162	21	23	0.83
3AB (P) 3.5	-R	3.5A	0.030	0.157	28	31	0.91
3AB (P) 4	-R	4A	0.026	0.154	36	40	1.0
3AB (P) 5	-R	5A	0.020	0.146	63	70	1.2
3AB (P) 6	-R	6A	0.015	0.139	107	123	1.4
3AB (P) 7	-R	7A	0.013	0.135	141	162	1.6
3AB (P) 8	-R	8A	0.012	0.132	184	214	1.7
3AB (P) 10	-R	10A	0.009	0.125	316	372	2.0
3AB (P) 15	-R	15A	0.006	0.124	845	1023	2.8

Consult manufacturer for other ratings

Mechanical Dimensions

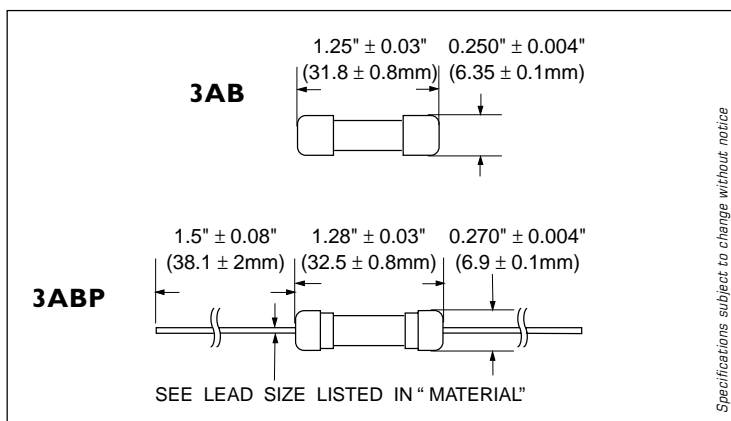

Specifications subject to change without notice

ORDERING INFORMATION SEE LAST 2 PAGES

Type 3AB / 3ABP
Fast Blow Fuse Series

1/4 x 1 1/4 inch Ceramic Tube

3ABC1005

3AB / 3ABP - TIME CURRENT CHARACTERISTIC CURVE

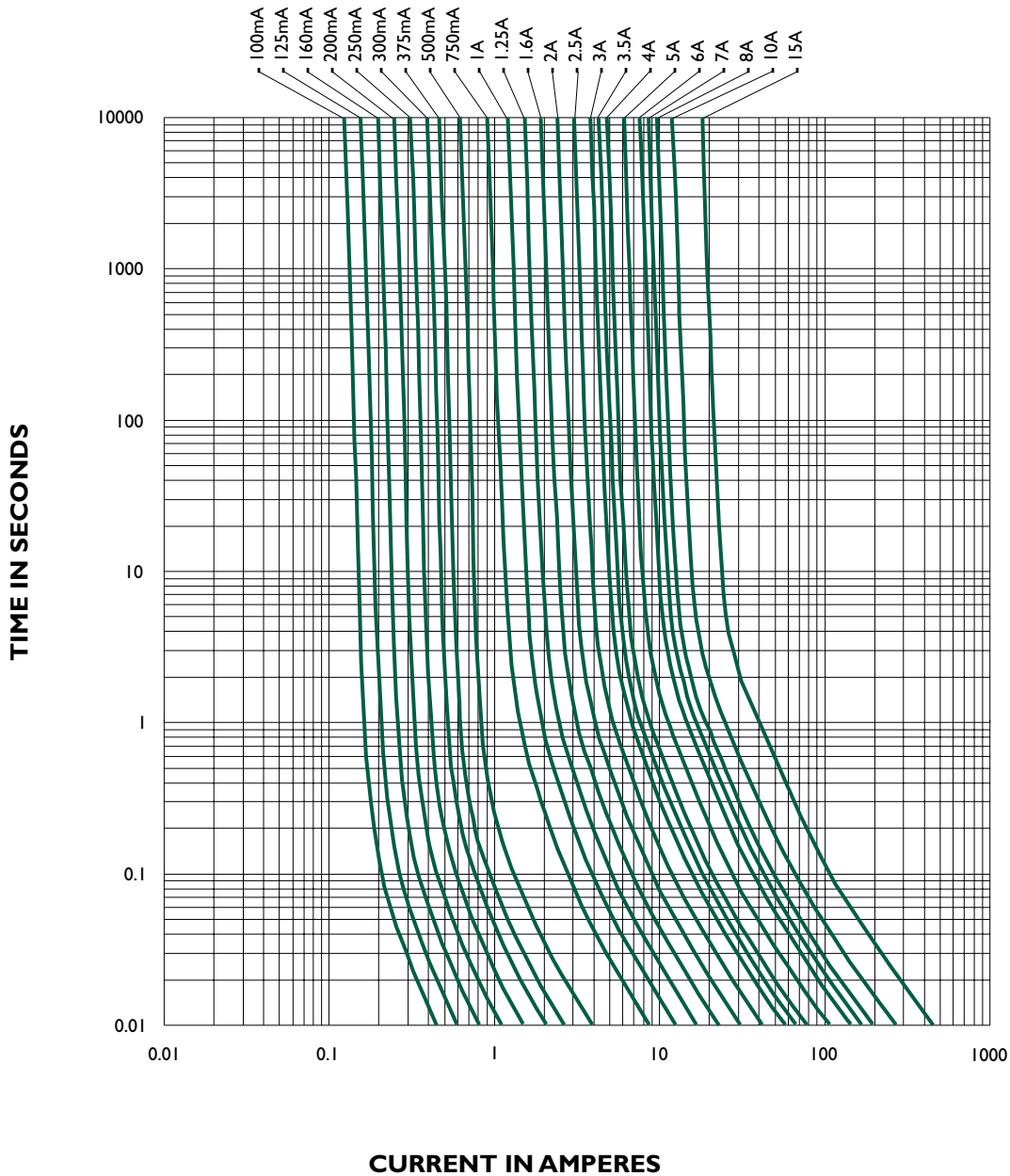

Specifications subject to change without notice

NOTE - see important information under "User Guide" on P.08

Corporate Office
Bel Fuse Inc.
206 Van Vorst Street, Jersey City, NJ 07302
Tel: 201-432-0463
Fax: 201-432-9542
E-Mail: belfuse@belfuse.com
Website: www.belfuse.com

Far East Office
Bel Fuse Ltd.
8F/8 Luk Hop Street
San Po Kong
Kowloon, Hong Kong
Tel: 852-2328-5515
Fax: 852-2352-3706

European Office
Bel Fuse Europe Ltd.
Preston Technology Management Centre
Marsh Lane, Preston PR1 8UD
Lancashire, U.K
Tel: 44-1772-556601
Fax: 44-1772-888366